

Hydronix

Hydro-Probe BX

Digital Microwave Sensor for
Measuring Moisture or Dissolved Solids



**SUGAR PRODUCTION
POWDERED DRINKS · LIQUIDS**

Hydro-Probe BX

Microwave sensor for moisture or dissolved solids

The Hydro-Probe BX is a high temperature microwave sensor designed for use in liquids such as concentrates, solutions or any process where the level of moisture or dissolved solids requires measurement.

Features

- Designed for installation in a pressurised environment
- Digital technology provides precise linear moisture measurement
- Advanced Digital Signal Processing provides a clear signal with rapid response
- Averaging and signal smoothing functions
- Configurable digital inputs / output
- Configurable alarms
- Fast response to changing conditions with 25 measurements per second
- Consistent performance with no need for recalibration except for use with different materials
- Stand alone or simple integration into a new or existing automation system
- Self-cleaning option

Connectivity

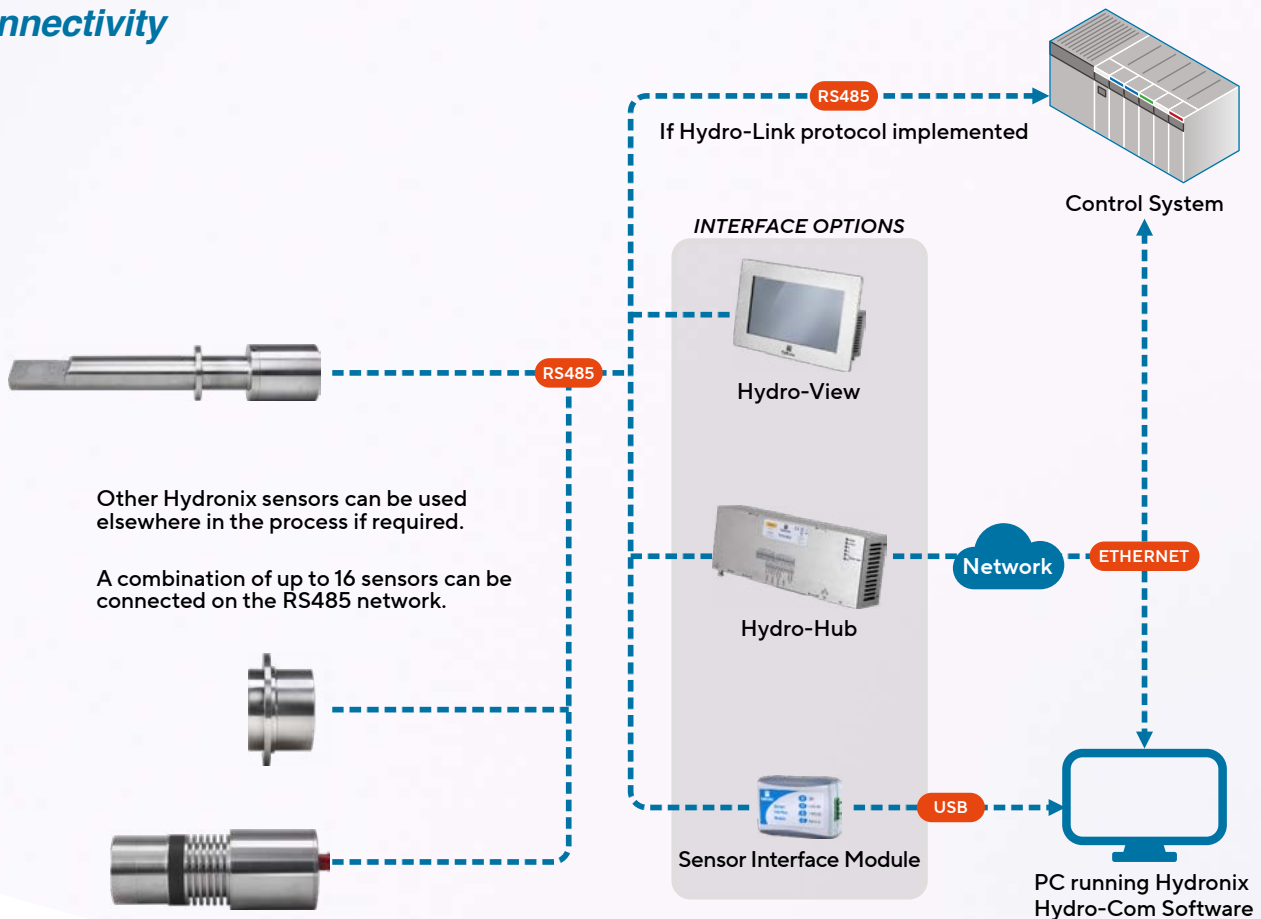

Typical Applications

Hydronix sensors can be used in many industries that require in-line measurement of moisture or dissolved solids in real-time.

This allows control systems to achieve process targets with highly repeatable precision.



Reducing Liquids

The concentration of a liquid in an evaporation process can be measured to enable intermediate product to be output correctly to subsequent process stages.



Sugar Production

The sensor can measure Degrees Brix during sugar refining processes where the sugar is still in the liquor stages.

Typical Installations

The Hydro-Probe BX can be mounted into a vacuum pan, pipeline or vessel.

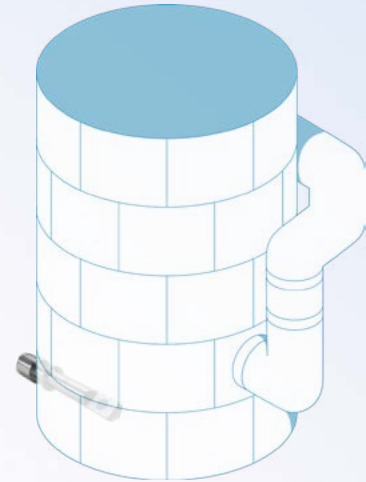

Self Cleaning

The Hydro-Probe BX-SC features an internal pipe allowing water to be flushed over the ceramic faceplate to remove built-up material. This can be connected to the plant water system using standard 6mm fittings.



Display and Control Options

Hydronix has a range of display and control options.

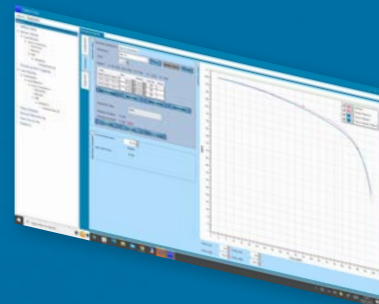

Configure and Calibrate

Easily configure & calibrate the sensor using Hydro-Com Software.

Technical Information

Construction

Body: 316 Stainless Steel.
Faceplate: Ceramic.
O-Rings: EPDM.
HPBX-SC01 pipe fittings: 6mm

Fixing

The sensor must be placed in the flow of material and is attached to the vessel using the bolted flange.

Measurement Range

Moisture: 0-100%, material dependant.

Brix: >50° Bx.

Penetration of Field

Approximately 75-100mm, material dependant.

Operating Temperature

Materials Section: 0 to 125°C.

Electronics Section: 0 to 60°C.

The sensor will not measure ice.

Refresh Rate

25 times per second.

Analogue Outputs

Two configurable 4-20mA or 0-20mA current loop source available for Unscaled, moisture, Brix or material temperature.

Digital (Serial) Communication

Modbus.

Opto-Isolated RS485 2-wire port. RS232, Ethernet and USB adaptors available.

Programming details to access sensor values and parameters are available on request.

Discrete Input/Output

One input, one configurable I/O.

Environmental

Pressure: Full vacuum to 6 Bar gauge.

Electronics Section Protection: IP67.

Cleaning system: 1 to 2 Bar, 80°C max, filtered water.

Extension Cable

Up to six twisted pairs, 22AWG, 0.35mm² conductors. Screen braid with 65% minimum coverage plus aluminium/polyester foil.

100m maximum cable.

Power Supply

+15V to +30V DC, 200mA max operating, 1 Amp startup.

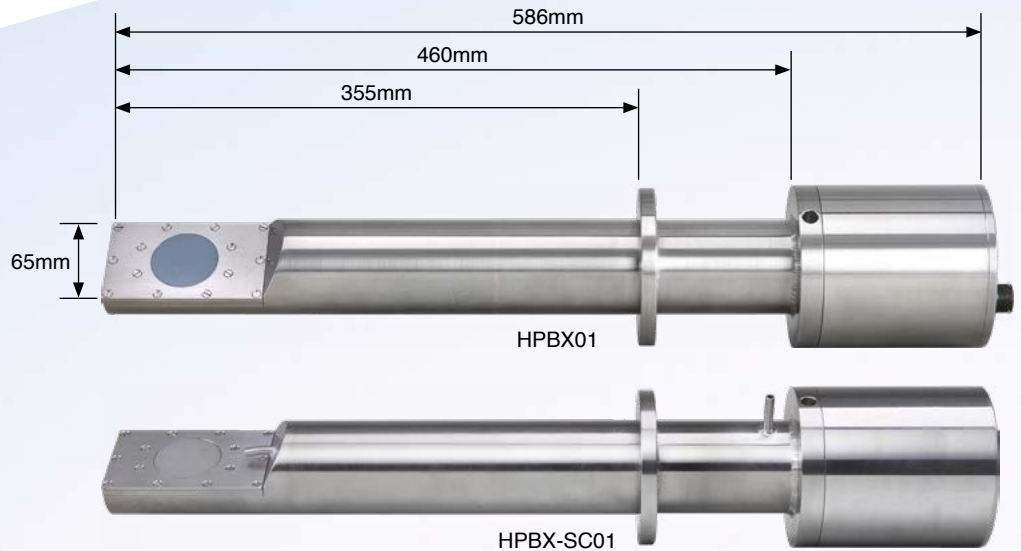

Hydronix

Head Office – United Kingdom

Tel: +44 (0)1483 468900

Email: enquiries@hydronix.com

Central Europe & Southern Africa

Tel: + 49 2563 4858

France

Tel: + 33 652 04 89 04

America, Spain & Portugal

Tel: +1 231-439-5000

hydronix.com

Part Number	Description
HPBX01	Hydro-Probe BX
HPBX-SC01	Hydro-Probe BX with self-cleaning system
3010	Mounting Boss
3020	PTFE Gasket for mounting flange
3050	HPBX-SC01 pipe fitting kit
0975A	4m Sensor Cable
0975AT	Sensor cable with network termination (4, 10, 25 and 50 meters)
BXEW	4 Year extended warranty option